

RIDI GROUP UK

PERFORMANCE-CBS

Modular AC/DC Central Battery System



RG ADDITIONS

RESPONSIBLE LIGHTTM
RIDI GROUP UK



RG-PERFORMANCE CBS

RG-P-CBS SYSTEM OVERVIEW

The RG-P-CBS central power supply system is an advanced, reliable and user-friendly central battery system, designed in compliance with the requirements of VDE 0108, PN-EN 50171 and PN-EN 50172 standards.

The system provides the possibility of monitoring circuits, luminaires or both.

A RG-P-CBS unit is equipped with a controller to supervise the operation and status of the entire system, and to register all events according to the requirements specified in PN-EN 50172. A wide range of luminaire control options enables easy modification of functions as and when required by the user. The operating mode of a luminaire is set at the controller or via SMART VISIO software application and in either case the required mode can be configured at any time. A built-in timer can also be used to activate, for example, the nighttime mode of a luminaire.

The system comprises an intelligent charger which controls the charging process and protects the batteries from damage, and thanks to the use of an active PFC function, fixed costs of operation are considerably reduced.

The RG-P-CBS can be flexibly adapted to any building or facility by diversifying the power supply plan of fire zones or the routing of emergency lighting circuits by implementing RG-P-CBS LPS or RG-P-CBS PBS substation systems, respectively.

The whole system will not fail if the central control unit is damaged, because its substations will take over the control of branch circuits and luminaires, which considerably increases the safety level in the building or facility.

Routine periodic tests, the event log and system configuration data can be stored on an SD memory card provided with the unit. Additionally, all that data is stored in the non-volatile memory of the control unit.

With the safety of firefighting and rescue teams in mind, in all CBS units the IT earthing system



Features:

- Modular design for quick assembly
- Freely-programmable operating modes for each circuit (circuit monitoring)
- Freely-programmable operating mode for each luminaire, irrespective of the circuit settings
- Monitoring of each luminaire and circuits
- Possibility to adapt the system to the layout of fire zones
- Possibility to assign a text description to each luminaire, circuit and control modes
- Four fully-programmable function keys
- Four keys with preset functions
- Temperature and voltage monitoring of single accumulator



SMART TECHNOLOGY

SWITCHING METHOD AND REVISION TECHNOLOGY

A conventional installation requires that the operating mode of each circuit is specified as early as at the design stage. Any possible changes or errors may incur extra costs or even make necessary corrections impossible.

In order to eliminate such inconveniences, RG-P CBS's manufacturer, AWEX, has introduced a new fully automatic technology to monitor and control each luminaire in a circuit:

**Switching
 Method
 And
 Revision
 Technology**

The SMART enables installation of luminaires operating in three different modes: continuous, intermittent and switched, in a single circuit. Programming and control of the luminaires is provided by means of power supply cables and therefore no extra communication cables are required. The SMART functionality is available for luminaires fitted with appropriate ADS address modules. The operating modes are set up from the main controller and no adjustments have to be made at the luminaires.

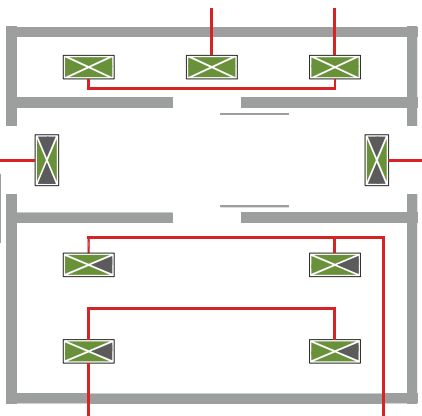
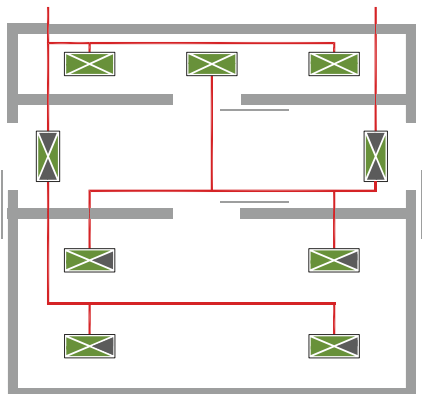

SMART ADVANTAGES:

- Installation of luminaires operating in different modes within a single circuit
- Flexible design and installation
- Smaller number of circuits
- Lower installation costs
- Operating modes of the luminaires can be changed at any time

CONVENTIONAL LIMITATIONS:

As compared with the SMART system, a conventional system has the following limitations:

- Only one operating mode is available in the branch circuit
- Higher installation costs
- Higher costs of subsequent changes
- Operating mode is difficult or impossible to change

RG-P-CBS LBS SYSTEM DESCRIPTION

The RG-P-CBS LBS is a state-of-the-art, reliable and user-friendly central battery system manufactured by AWEX for RG Additions' RG-P-CBS range. It has been designed to meet applicable standards and comprises the proprietary SMART technology. From the functional point of view, the RG-P LBS is equivalent to the RG-P-CBS, however due to its compact size and reduced power output it is intended for smaller-sized locations or in places where the power sources of emergency luminaires must be diversified (as a group). The RG-P-CBS LPS can power luminaires with a total power output of 1500W for 1h or 500W for 3h. Thanks to four sensor

inputs provided in the control module, fire zones can be managed by means of phase loss sensors (CZF) which monitor the voltage of the power supplied to the zones. The system is upgradable with ELS230 modules with 9 potential control inputs. Line modules have separate protection for AC and DC mode, which considerably increases the safety of emergency lighting activation in the building/facility. In the DC mode, the system operates as an IT network (insulated).



Features:

- Automatic performance of tests
- Automatic detection and integration of new luminaires
- Circuit monitoring
- Luminaire monitoring
- Luminaire programming and setting up from the system controller
- Communication with luminaires via power supply cable
- SMART technology (adjustable luminaire modes)
- Separate AC and DC voltage for each output circuit in changeover module
- Connection and an SD card to save, transfer and print emergency lighting system reports, according to PN-EN 50172
- Possibility to save system settings (back-up) on an SD memory card
- Nighttime mode
- Controlling of luminaires and system functions by means of 24V and 230V connections (internal and external)
- Monitoring of the power supply at distribution switchboards and individual lighting circuits
- USB port
- RJ45 connector for direct communication with any computer via Ethernet
- System status check by using any website browser
- System management and visualization by using dedicated SMART VISIO software
- Powering up luminaires with a total power output of 1500W for 1h or 500W for 3h

RG-P CPS CM-NET CONTROL MODULE

The RG-P-CBS CM-NET control module supervises and manages other modules included in the central battery system. The keys and LCD display on the front panel enable the user to set up and operate the system. System configuration is also possible through the RJ45 connector and the SMART VISIO installed on a PC. The LEDs on the front panel provide immediate visual information on the current status of the central battery system. The control module supervises the following functions: mains/battery power supply mode, battery charging, system current and voltage, insulation condition, and deep-discharge protection. Detection of a fault or error is immediately indicated and registered in the event log.

The occurrence of a short circuit or break in communication wires triggers automatic switchover of all circuits to the emergency mode. The module also offers the function of automatic searching and adding of all luminaires connected to the system. The controller enables making firmware upgrades of all internal system modules, as well as address modules. Thanks to a timer function, the operating mode of a luminaire can be changed according to its assigned, configurable program. The control module has programmable function keys which can be used to switch the system immediately into the service mode or the IT mode.



Features:

Configuration:

- Eight configuration keys
- SD card
- RJ45 connector for SMART VISIO

System control:

- Four 24V potential-free inputs that can be programmed for: functional test, battery test, sensor input etc.
- Four function keys:
 - Lock
 - Functional test activation
 - Battery test activation
 - Deep discharge error reset
- Four programmable function keys:
 - Switching circuits for AC power supply
 - Switching circuits for DC power supply
 - Alarm reset: leakage fault
 - Alarm reset: emergency mode
 - Functional test without preheating
- Three LON communication buses
- 2 timers
- 3PH phase loss sensor connector
- Remote system lock input

External communication:

- Current system status indication
- LED indicators
- LCD display
- BMS – BACnet, LonWorks
- Three potential-free outputs for PZS or BMS



RG-P-CBS CM-NET CONTROL MODULE

Technical specifications	
Display	Graphic LCD 128x4
Keypad	8 function keys and 8 control keys
LED indicators	<ul style="list-style-type: none"> 4 LED indicators • mains supply mode • battery supply mode • fault • deep discharge
Interfaces	<ul style="list-style-type: none"> • SD/MMC cards • RJ45 – BACnet • LON x 3 – Lonworks
Potential-free inputs	<ul style="list-style-type: none"> • locks • phase loss sensor • 4 programmable inputs
Outputs	• 3 programmable relay outputs 24V/0.5A
Acoustic signalling	programmable buzzer
Displayed information	<ul style="list-style-type: none"> • mains voltage • battery voltage • battery charge current (+) • battery discharge current (-) • date and time • type of test in progress • charging disturbance/error • deep discharge • manual reset • recovery delay • insulation failure • circuit failure • circuit overload • fuse failure • substation failure • circuit and control names • system and control parameters • communication errors • event log review (including substations) • switching substation failure • active critical groups • type of system lock
Event log	Registered on an SD card; reading and printing without dedicated software

RG-P-CBS CCM CHARGING CONTROL MODULE

RG-P-CBS CCM module is responsible for accumulators charging process. Charging process is realized by BST - 430W booster.

It's possible to use larger accumulators by increasing quantity of BST - 430W booster, up to 16 pcs.



Features:

- Supporting and controlling the RG-P-CBS BST-430 charge booster
- Monitoring leakage conductance in branch circuits
- Protection against deep discharge
- The ability to control individual batteries in cooperation with BC battery control system
- Fan control
- Two connectors for the measurement of:
 - current
 - temperature
- RS interface for communication with the BC system
- Displaying the current status of the charger
- Three programmable potential-free outputs
- Status indicator LED

Technical specifications	
LED indicators	<ul style="list-style-type: none"> • Battery fault • Leakage fault • Stand by • Fault • Status
Protection against deep discharge	183,6V DC
Outputs	• 3 programmable relay
Max. Booster	16 pcs

RG-P-CBS BST 430 - BOOSTER

The RG-P-CBS Booster module ensures battery charging on the basis of UI characteristic with temperature compensation according to PN-EN 50171. The charging algorithm of the charger is supervised by the control module. The charger is equipped with an internal active PFC module, which guarantees that the power factor is close to 1.0 ($\lambda \approx 1$).

The booster is used for charging batteries with the voltage rated at 216V. The maximum power of the charger is 430W.



Technical specifications		
Charging voltage	Boost charging Float charging	265V DC 246V DC
Max. power Booster		430W ± 5%
Max. current Booster		2A ± 5%
LED indicators	<ul style="list-style-type: none"> • Charging • Redy • Fault • Status 	
Protection against deep discharge		183,6V DC

RG-P-CBS ML-E 2X6A CIRCUIT MODULE

The 2x6A module supplies power to one branch circuit.



Features:

- Controlling SMART luminaires
- Monitoring up to 20 luminaires per circuit
- Unique addresses programmed during production process
- Freely programmable work mode
- Independent control of each circuit
- Independent control of each luminaire
- Identification of each luminaire
- Fault, module status and circuit status indicators
- Service pin
- Supplying luminaires with PN-EN 60347-2-7 ballasts and luminaires with LED and incandescent light sources
- Adjustable AC/DC changeover time

Technical specifications

Number of circuits	2
Max. circuit length	up to 600m
Max. load	6A
Max. inrush current	180A/ms
Switch-over time	100 - 2500ms
Fuse	2x10AT / 250V / 6,3x32

RG-P-CBS ML-E 4X3A CIRCUIT MODULE

The 4x3A module supplies power to two branch circuits.



Features:

- Controlling SMART luminaires
- Monitoring up to 20 luminaires per circuit
- Unique addresses programmed during production process
- Freely programmable work mode
- Independent control of each circuit
- Independent control of each luminaire
- Identification of each luminaire
- Fault, module status and circuit status indicators
- Service pin
- Supplying luminaires with PN-EN 60347-2-7 ballasts and luminaires with LED and incandescent light sources
- Adjustable AC/DC changeover time
- Adjustable emergency duration for each circuit

Technical specifications

Number of circuits	4
Max. circuit length	up to 600m
Max. load	3A
Max. inrush current	180A/ms
Switch-over time	100 - 2500ms
Fuse	8x5AT / 250V / 6,3x32

RG-P-CBS ML-E 8X1,5A CIRCUIT MODULE

The 8x1,5A module supplies power independently to four branch circuits.



Features:

- Controlling SMART luminaires
- Monitoring up to 20 luminaires per circuit
- Unique addresses programmed during production process
- Freely programmable work mode
- Independent control of each circuit
- Independent control of each luminaire
- Identification of each luminaire
- Fault, module status and circuit status indicators
- Service pin
- Supplying luminaires with PN-EN 60347-2-7 ballasts and luminaires with LED and incandescent light sources
- Adjustable AC/DC changeover time
- Adjustable emergency duration for each circuit

Technical specifications

Number of circuits	8
Max. circuit length	up to 600m
Max. load	1,5A
Max. inrush current	180A/ms
Switch-over time	100 - 2500ms
Fuse	16x2,5AT / 250V / 6,3x32

RG-P-CBS HUB MODULE

The Lon Hub module is a component of the RG-P central battery system. It is installed in PBS-20/H substations, PBS-40/H. The module is designed to enable communication of the CM-NET control module with

line modules installed in substations (remote cabinets). The LON3 interface is used for communication with the main cabinet.



Features:

- Communication with up to 5 RG-P-CBS modules: ML-S line modules and LS 24 or LS 230 sensor modules
- Service pin
- Address setting switch to set the HUB module address within the range of 1-10
- Power supply of up to 5 modules
- Built-in termination of a communication line
- Fault and module status indicators
- Push-buttons to: add/remove, select and configure modules

Technical specifications

Number of addresses	1-10
Number of supported modules	5
Connectors	<ul style="list-style-type: none"> • LON in – LON3 bus input • LON out – LON3 bus output • Term – for bus termination activation

RG-P CBS LS-24 SENSOR MODULE

This potential-free input module monitors up to 8 inputs in a 24V current loop. The inputs enable selective activation of luminaire control groups by assigning phase loss sensors to them. In the event of a voltage loss at the primary lighting switchboard, luminaires with control groups assigned to them are activated.



The inputs can also be used as potential-free inputs for building management systems (BMS) to activate individual control groups. The system can integrate up to 10 RG-P-CBS modules of the LS-24 and LS-230 type.

Features:

- Monitoring of the phase loss sensor current loop
- Monitoring of the 24V DC current loop
- Possibility of joint control with a BMS via potential-free inputs
- Programmable recovery delay
- Service pin
- Fault and module status indicators
- Active input indicators
- Possibility of sensor input negation

Technical specifications	
Number of inputs	Eight 24V current loop inputs
Recovery delay	from 1 s to 1 h
Connectors	2,5mm ²

RG-P-CBS LS-230 SENSOR MODULE

The module has eight 230V AC potential-free inputs. It enables setting up emergency luminaire control groups with the power supply of primary lighting circuits. The logic of the inputs can be inverted, so that the input is in active state at 0V and inactive at 240V. This functionality enables monitoring of individual protections of the primary lighting system.



The inactive state recovery delay time is programmable within the range of 1 second to 1 hour. The system can integrate up to 10 RG-P CBS modules of the LS-24 and LS-230 type.

Features:

- Monitoring of primary lighting switches
- Programmable inversion of input logic
- Possibility of monitoring individual primary lighting protections
- Programmable recovery delay time
- Service pin
- Fault and module status indicators
- Input status and inversion indicators

Technical specifications	
Number of inputs	Eight 230V AC potential inputs
Recovery delay	from 1 s to 1 h
Connectors	2,5mm ²

RG-P-CBS ELS-230V EXTERNAL MODULE

The ELS-230V sensor module is used for monitoring of 230V AC potential signals from primary lighting switches in order to activate an emergency luminaire control group along with the primary lighting. The module has 9 inputs. The inputs can be inverted to monitor individual circuit protections. The ELS-230 module can also serve as a phase loss sensor. The control inputs can be assigned the recovery delay function.



The module has a service pin, rotary address selector switches, a LON connector for data transmission (with a built-in terminating resistor) and a 24V power supply connection. The module is also equipped with LED indicators displaying the current logic settings and the status of individual inputs.

Features:

- Monitoring of primary lighting switches
- Function of a phase loss sensor
- Programmable inversion of input logic
- Possibility of monitoring individual primary lighting protections
- Programmable recovery delay time
- Service pin
- Fault and module status indicators
- Input status and inversion indicators

Technical specifications

Power supply	24 V DC ± 5V
Protection class	I
Ingress protection	IP21
Operating temperature range	-10°C to + 40°C
Potential inputs	9 isolated inputs
Phase loss control	Monitoring of up to 3 phases
Recovery delay	from 1 s to 1 h
Data transmission	LON
Number of addresses	1-32
Switching threshold	as per 60598-2-22
Dimensions (LxWxD) mm	105x85x60
Connectors	2,5mm ²

RG-P-CBS CZF LON EXTERNAL MODULE

The CZF LON sensor module is used for monitoring of 230V AC potential signals from primary lighting switches in order to activate an emergency luminaire control group along with the primary lighting. The module has 3 inputs. The inputs can be inverted to monitor individual circuit protections. The CZF LON module can also serve as a phase loss sensor. The control inputs can be assigned the recovery delay function.



The module has a service pin, rotary address selector switches, a LON connector for data transmission (with a built-in terminating resistor) and a 24V power supply connection. The module is also equipped with LED indicators displaying the current logic settings and the status of individual inputs.

Features:

- Monitoring of primary lighting switches or functioning as a phase loss sensor
- Programmable inversion of the action logic of individual inputs
- Possibility of monitoring individual primary lighting protections
- Programmable recovery delay time
- Service pin
- Fault and module status indicators
- Input status indicators

Technical specifications

Power supply	24 V DC ± 5V
Protection class	I
Ingress protection	IP21
Operating temperature range	-10°C to + 40°C
Potential inputs	Three isolated inputs
Phase loss control	Monitoring of up to 3 phases
Recovery delay	from 1 s to 1 h
Data transmission	LON
Number of addresses	1-32
Switching threshold	as per 60598-2-22
Dimensions (LxWxD) mm	55x90x60
Connectors	2,5mm ²

RG-P-CBS CZF-01 PHASE LOSS SENSOR

The quick-acting phase loss sensor is used for voltage monitoring in primary lighting switchboards to energise specific circuits or the whole system for emergency operation.



The switching threshold is as specified in PN-EN60598-2-22.

Features:

- Phase loss detection
- Switch activation detection
- Switchover threshold as per PN-EN 60598-2-22
- Delay time <200 ms
- Mounting in DIN-3 rail

Technical specifications	
Power supply	230V, 50Hz, 176V-275V DC
Switchover thresholds	As per PN-EN 60598-2-22
Mounting	DIN-3 rail (TH35)
Delay time	< 200ms
Connectors	2,5mm ²
Contact	230V/50Hz 0,5A NO

RG-P-CBS ETA 2 SWITCHING MODULE

ETA-2 is an external module supplied from the central battery system (RG-P-CBS). It is used for switching single luminaires or a group of luminaires connected to outputs OUT1 and OUT2. If a phase loss sensor and a 216V DC emergency lighting switch are triggered, the module always activates both outputs. In other circumstances, the activation of those outputs depends on the manually set up operating modes. In the case of a 230V AC power supply, OUT2 is activated depending on the settings of a CS or BUS mode. In the CS mode, OUT2 is activated by a switch. In the BUS mode, the output is always active to enable controlling external luminaires, for example by means of a DALI controller.



The OUT1 can be set up to work in three operating modes: always ON (maintained operation), always OFF (non-maintained operation) or depending on the status of the switch. Luminaires connected to OUT1 can also be controlled by an external controller operating in the BUS mode when the output is always active.

Features:

- Phase loss detection
- Switch activation detection
- Emergency mode detection
- Fault indication by relay closure
- Multiple operating modes: relay outputs activated depending on switch settings

Technical specifications	
Power supply	220 - 240V 50-60Hz, 216V DC ± 20%
Ingress protection	IP20
Protection class	I
Max. power	920 VA
Potential outputs	1x1A, 1x4A
Wire terminals	max. 2,5mm ²
Temperature range	-10°C to +40°C
Mounting	DIN rail
Dimensions (LxWxD)	88x90x58mm
Weight	0,1kg

RG-P-CBS MP 500 SWITCHING MODULE

The MP500 is used for activating the mains supply mode of a luminaire of a group of luminaires by means of a primary lighting switch. The module

enables application of primary lighting luminaires as emergency luminaires.



Module dimensions in mm

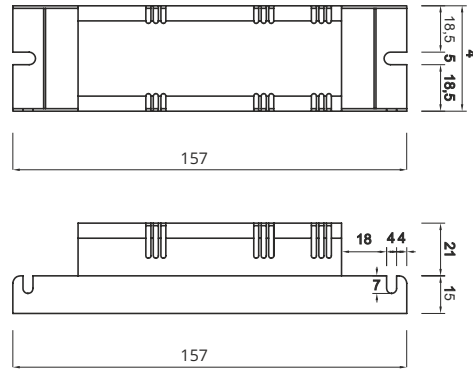

Technical specifications

Power supply	230V 50Hz, 216V DC ± 20%
Ingress protection	IP20
Max. power	500 VA
Wire terminals	3x2,5mm ²
Max. Ambient temperature range	-10°C to +40°C
Mounting	Inside the luminaire
Weight	0,1kg

PHASE LOSS	ON OFF	POWER		ON	OFF
		TO	CB		
NO	ON	~230V AC	0V	ON	ON
NO	OFF	~230V AC	0V	OFF	OFF
YES	ON	~0V	~230V DC	ON	OFF
YES	OFF	~0V	~230V DC	ON	OFF

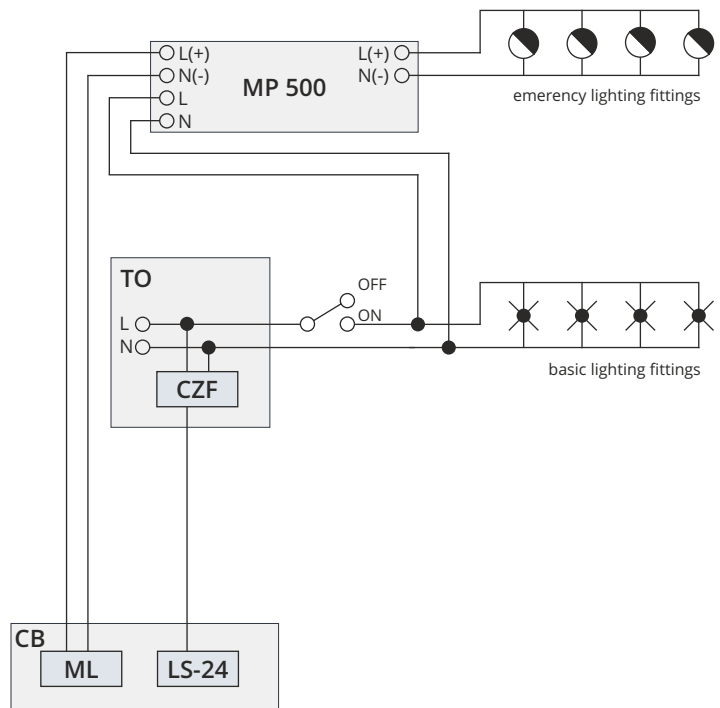

- CB – Central battery
- ML – Linear module input
- CZF – Phase loss sensor
- TO – Basic lighting switch board
- MP500 - switching module
- LS-24 – Potential free input module

RG-P-CBS MP 4A SWITCHING MODULE

The MP 4A is used for activating the mains supply mode of a luminaire of a group of luminaires by means of a primary lighting switch. Thanks to the applied logic (see Fig. below) of the control input, when the

primary lighting fails all luminaires in this group are switched to the emergency mode.



Module dimensions in mm

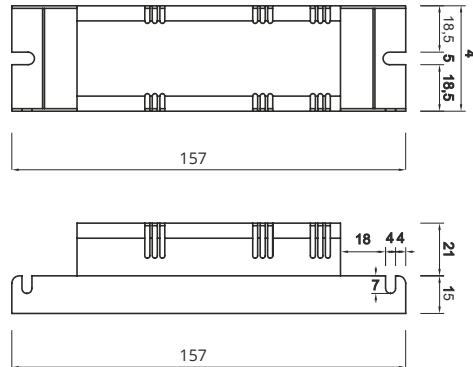

Technical specifications

Power supply	230V 50Hz, 216V DC ± 20%
Ingress protection	IP20
Max. load	4A
Wire terminals	3x2,5mm ²
Max. Ambient temperature range	-10°C to +40°C
Mounting	Inside the luminaire
Weight	0,1kg

PHASE LOSS	Pos. 1	Pos. 2	CB POWER SUPPLY	ON	OFF
NO	Pos. 1	○	230V AC	ON	OFF
NO	Pos. 2	○	230V AC	OFF	ON
YES	Pos. 1	●	230V DC	ON	OFF
YES	Pos. 2	●	230V DC	ON	OFF

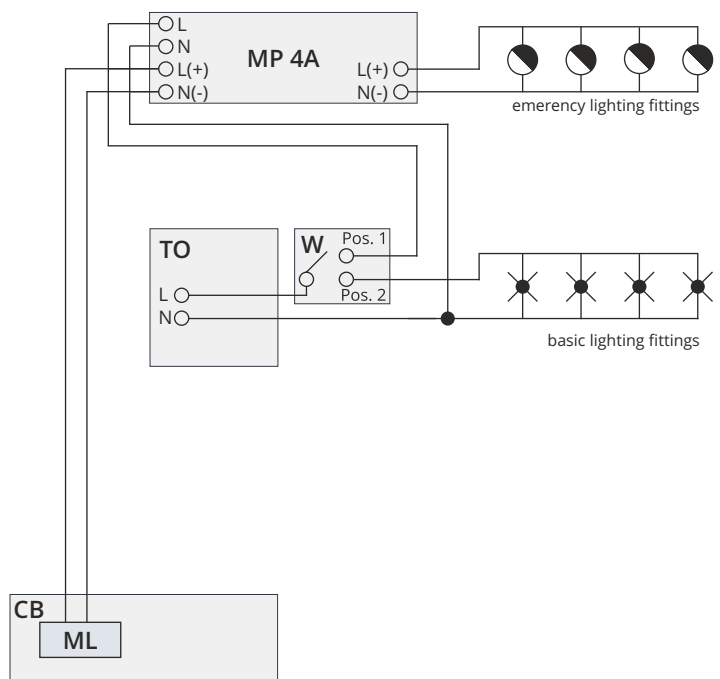

- CB – Central battery
- ML – Linear module input
- CZF – Phase loss sensor
- TO – Basic lighting switch board
- MP 4A - switching module
- W - single-pole double-throw switch

RG-P-CBS PZS LON MODULE

The PZS LON module is used for monitoring of Central Battery Systems connected via LON buses. Thanks to the PZS LON module the user can check the name and the status of the connected system. Additionally, all faults and errors that have occurred in each of the connected systems can be viewed.



The module has an LCD display and LEDs indicating: AC operation, DC operation, Lock, Fault; the panel is equipped with 5 push-buttons and a key.

Features:

- Reading and viewing the current status of all systems connected to the module
- Plug & Play device – no configuration required
- System monitoring within a single group (up to 10 systems); selection of 1-4 groups
- Possibility of locking all connected system components by pushing the Block button
- Configurable lock for selected systems (not all systems have to be locked by the module; monitoring only possible)
- Configuration is saved when the power supply is interrupted
- Loss of communication is notified by the module (timeout)
- Loss of communication with the system removes any previously applied locks
- Acoustic signalling of system faults or errors (can be postponed for a specific time)
- LED indicators on the front panel: AC supply mode, DC supply mode, Lock, Fault
- LED status depends on all monitored systems

Technical specifications

Power supply	24 V DC ± 5V
Protection class	I
Ingress protection	IP21
Operating temperature range	-10°C to +40°C
Number of monitored systems	from 1 to 10
Data transmission	LON
Connectors	1,5mm ²
Max. dimensions (HxWxD)	130x100x40mm
Mounting	Wall-mounted

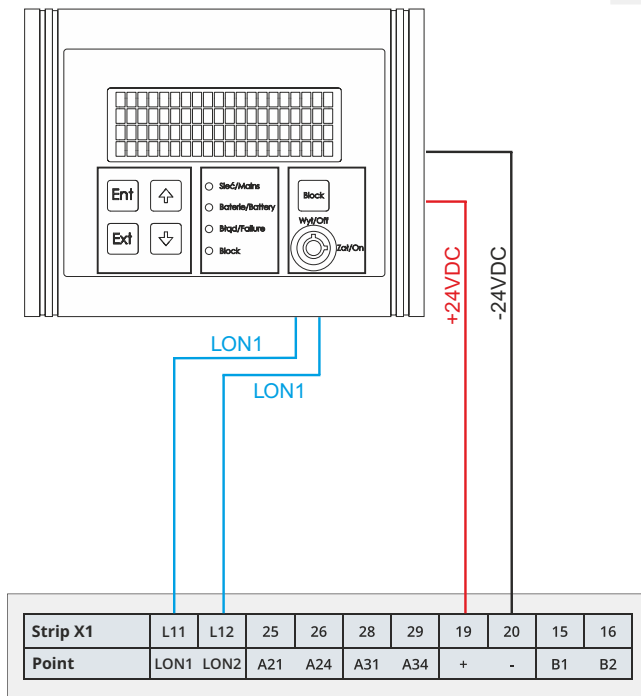

RG-P-CBS PZS MODULE

This panel enables remote checking of some basic operating statuses of the system, such as: stand-by (mains operation), battery operation or fault.

A built-in key can be used to lock continuous and emergency operation. This prevents the system from unauthorized tampering.



Technical specifications	
Connectors	1,5mm ²
Max. dimensions (HxWxD)	82x80x55mm
Mounting	Wall-mounted

Connection of the PZS module

Switch ON	- lock applied
Switch OFF	- lock removed
Loop control	- lock is removed in case of a short or open circuit

RG-P-CBS SD MEMORY CARD

An SD memory card enables saving the event log and subsequent opening and printing it on a PC with standard word processing software.

Using the card, the system configuration can also be stored and the firmware can be updated.



Data saved on the card:

- Text description of the system
- Description of each circuit
- Description of each luminaire
- Description of each control mode
- Description of each control group
- Complete configuration of the system
- Event log
- Firmware



RG-P-CBS SYSTEM STRUCTURE

Communication with ELS 230V external modules, substations with a controller and substations with a HUB module (remote cabinets) is based on the LonTalk communication protocol. Three LonTalk interfaces are implemented in the controller. The first - LON1 - is used for communication

between systems with a controller and BMS type systems. The LON2 interface is intended for communication with external sensor modules of the ELS 230 type, whereas LON3 is reserved for substations equipped with a HUB module.

Central battery system communication diagram

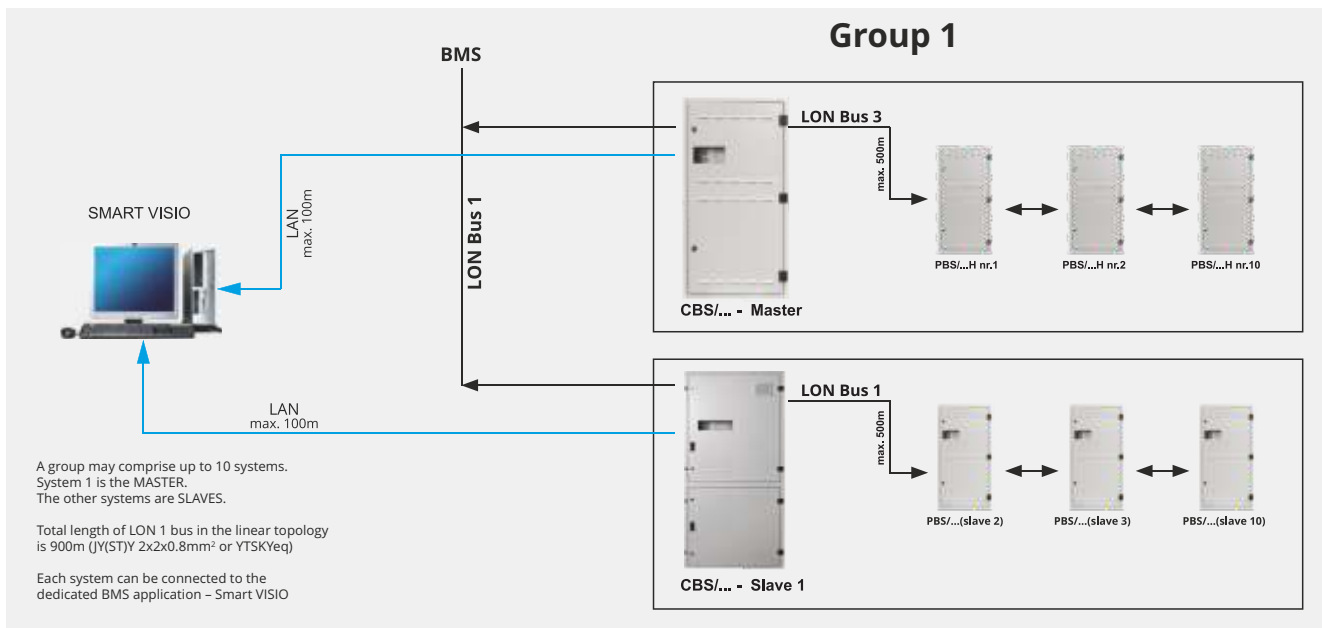
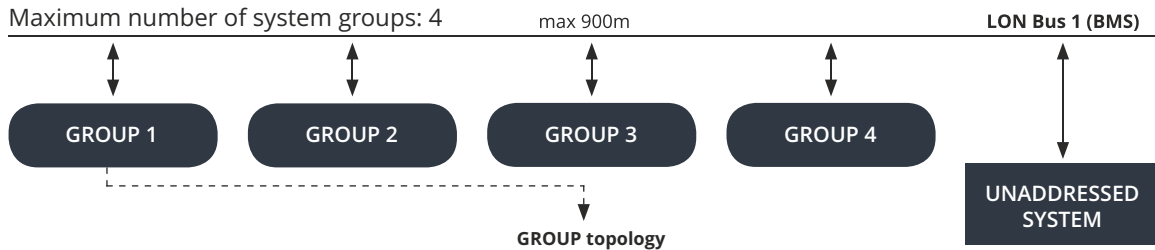

SYSTEM topology

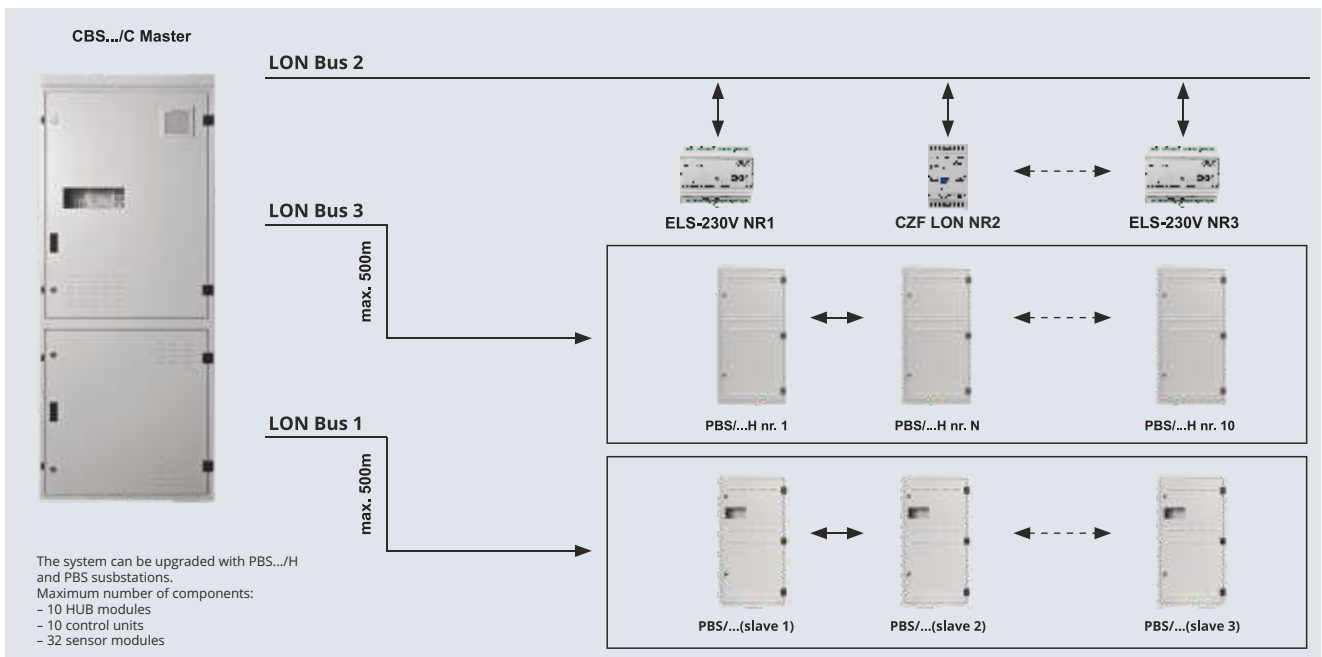

RG-P-CBS SAMPLE SYSTEM DIAGRAM

Central battery circuits

Central battery substation circuits

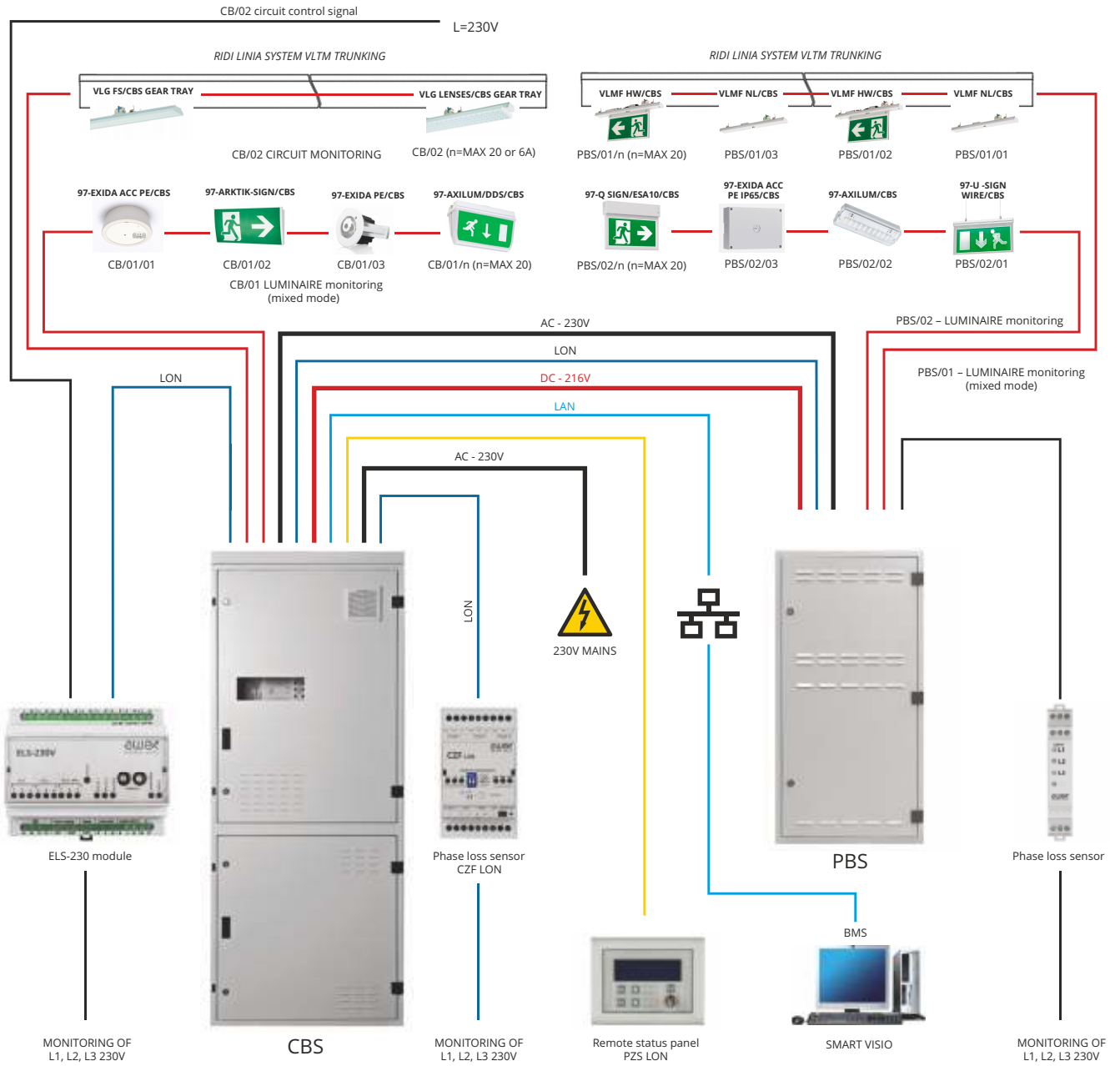

COMPARISON OF RG-P-CBS SYSTEMS CABINETS



	CBS/32L-E	CBS/80L-E	CBS/40C-E	CBS/48C-E	CBS/72R-E	CBS/48R-E	CBS/32C-E
Power supply parameters							
Mains voltage (3PH or 1PH)	400V/230V	400V/230V	400V/230V	400V/230V	400V/230V	400V/230V	230V
Frequency	50Hz	50Hz	50Hz	50Hz	50Hz	50Hz	50Hz
Earthing system	TN-S-C/IT	TN-S-C/IT	TN-S-C/IT	TN-S-C/IT	TN-S-C/IT	TN-S-C/IT	TN-S-C/IT
Technical parameters							
Dimensions (HxWxD) [mm]	2050x800x400	2050x800x400	2050x800x400	2050x800x400	1200x800x400	1200x800x400	1800x600x350
Material	Steel	Steel	Steel	Steel	Steel	Steel	Steel
Colour	RAL 7035	RAL 7035	RAL 7035	RAL 7035	RAL 7035	RAL 7035	RAL 7035
Door type	Right hand	Right hand	Right hand	Right hand	Right hand	Right hand	Right hand
Cabinet base	NO*(1)	NO*(1)	NO*(1)	NO*(1)	NO	NO	NO*(1)
Door lock	single-sided	single-sided	single-sided	single-sided	single-sided	single-sided	Single-sided
Electrical parameters							
Ingress protection	IP21	IP21	IP21	IP21	IP21	IP21	IP21
Protection class	I	I	I	I	I	I	I
Cable glands	top & bottom	top & bottom	top	top	top	top	top
Max. number of substations*(3)	6/2	6/2	2/ -	2/ -	2/ -	2/ -	1/ -
Mains power connection size	35mm ²	35mm ²	16mm ² *(2)	16mm ² *(2)	16mm ² *(2)	16mm ² *(2)	16mm ² *(2)
Battery connection size	35mm ²	35mm ²	16mm ² *(2)	16mm ² *(2)	16mm ² *(2)	16mm ² *(2)	16mm ²
Substation power supply connection size	16mm ²	16mm ²	10mm ² *(2)	10mm ² *(2)	10mm ² *(2)	10mm ² *(2)	10mm ²
Max. size of branch circuit connection	4mm ²	4mm ²	4mm ²	4mm ²	4mm ²	4mm ²	4mm ²
Max. length of branch circuit				600m			
Power parameters							
Max. system power	20kW	20kW	5,5kW	5,5kW	5,5kW	5,5kW	5,5kW
Max. main protection [A]	100	100	25	25	25	25	25
Max. substation protection [A]	63	63	10	10	10	10	10
Max. battery protection [A]	100	100	50	50	50	50	50
Equipment							
System controller	1	1	1	1	1	1	1
Power supply system 24V DC	1	1	1	1	1	1	1
Charging controller	1	1	1	1	1	1	1
Booster 430 W	1	1	1	1	1	1	1
Max. number of booster modules	16	9	2	2	4	2	1
Max. number of modules	5	12	7	7	11	7	6
Max. Number of circuits	32	80	40	48	72	48	32
Compact size	NO	NO	YES	YES	NO	NO	YES

RG-PERFORMANCE CBS



PBS/80-E	PBS/56-E	PBS/32-E	PBS/40-E	PBS/24-E	PBS/48H-E*(4)	PBS/32H-E	PBS/16H-E	LPS/24-E*(5)
400V/230V	400V/230V	230V	400V/230V	230V	230V	230V	230V	230V
50Hz	50Hz	50Hz	50Hz	50Hz	50Hz	50Hz	50Hz	50Hz
TN-S-C/IT	TN-S-C/IT	TN-S-C/IT	TN-S-C/IT	TN-S-C/IT	TN-S-C/IT	TN-S-C/IT	TN-S-C/IT	TN-S-C/IT
2050x800x400	1200x800x400	1200x800x400	1000x600x350	700x570x300	1000x600x350	700x570x300	500x420x300	1200x600x350
Steel	Steel	Steel	Steel	Steel	Steel	Steel	Steel	Steel
RAL 7035	RAL 7035	RAL 7035	RAL 7035	RAL 7035	RAL 7035	RAL 7035	RAL 7035	RAL 7035
Right hand	Right hand	Right hand	Right hand	Right hand	Right hand	Right hand	Right hand	Right hand
NO*(1)	-	-	-	-	-	-	-	-
Single-sided	Single-sided	Single-sided	Single-sided	Single-sided	Single-sided	Single-sided	Single-sided	Single-sided
IP21	IP21	IP21	IP21	IP21	IP21	IP21	IP21	IP21
I	I	I	I	I	I	I	I	I
top & bottom	top	top	top	top	top	top	top	top
-	-	-	-	-	-	-	-	-
35mm ²	16mm ^{2*(2)}	16mm ^{2*(2)}	16mm ^{2*(2)}	16mm ^{2*(2)}	16mm ^{2*(2)}	16mm ^{2*(2)}	16mm ^{2*(2)}	16mm ^{2*(2)}
35mm ²	16mm ²	16mm ^{2*(2)}	16mm ^{2*(2)}	16mm ^{2*(2)}	16mm ^{2*(2)}	16mm ^{2*(2)}	16mm ^{2*(2)}	16mm ^{2*(2)}
-	-	-	-	-	-	-	-	-
4mm ²	4mm ²	4mm ²	4mm ²	4mm ²	4mm ²	4mm ²	4mm ²	4mm ²
600m								
17kW	11kW	11kW	11kW	8kW	11kW	8kW	5,5kW	1,5kW
80	-	-	-	-	-	-	-	16
-	-	-	-	-	-	-	-	-
80	-	-	-	-	-	-	-	25
1	1	1	1	1	2xHUB	1xHUB	1xHUB	1
1	1	1	1	1	-	-	-	1
-	-	-	-	-	-	-	-	1
-	-	-	-	-	-	-	-	-
12	9	6	7	4	8	5	3	4
80	56	32	40	24	48	32	16	24
-	-	-	-	-	-	-	-	YES

(*1) Optionally, cabinets may be supplied with a 10 cm or 20 cm base

(*2) Special execution of a cabinet enables larger diameter connections with a reduced number of substations

(*3) Option; the number of substations depends on the type of power supply (1PH/3PH)

(*4) Remote cabinet, without a controller, equipped with a Lon HUB module

(*5) Optional execution of: LPS/4-E, LPS/8-E, LPS/16-E, LPS/24-E

RG-PERFORMANCE CBS

RG-P-CBS LUMINAIRES

RUFO 320/1300-840-CB / RG-P-CBS series

Luminaire type	Surface-mounted, wall, ceiling, 320mmØ diffuser
Light source; Output	LED 8W, 4000K; 9.5W, 1219 lm
IP Rating	IP40

RUFO 390/2500-840-CB / RG-P-CBS series

Luminaire type	Surface-mounted, wall, ceiling, 390mmØ diffuser
Light source; Output	LED 16W, 4000K; 19W, 2425 lm
IP Rating	IP40

*Other sizes/lm outputs available. 'RKSK' IP65 range & 'Z' flat cylindrical versions.

FPL2-EQ0595CBWS830840MPS0400 / RG-P-CBS series

Luminaire type	Recessed-mounted, ceiling, 595mm² MPS panel
Light source; Output	LED 32W, 3000/4000K; 33W, 3960 lm*
IP Rating	IP40

*Data shown is based on the factory default setting at 4000K & 3960lm. Lay in mounting without additional kit; Standard & bespoke frames on request

EDLR 195/2000-840 W-CB / RG-P-CBS series

Luminaire type	Recessed-mounted, ceiling, 195mmØ downlighter
Light source; Output	LED 14W, 4000K; 16W, 2066lm*
IP Rating	IP20*

EDLR 235/4000-840 W-CB / RG-P-CBS series

Luminaire type	Recessed-mounted, ceiling, 235mmØ downlighter
Light source; Output	LED 27W, 4000K; 31W, 4046lm*
IP Rating	IP20*

*Data shown for 'W' White reflector (Diffuser in transparent PC, Cw white trim) IP44, Closed disc accessory on request: SM matt, SO opal, SK clear or MPS prism. Coloured trims & special fixings on request. Other sizes/lm outputs available.

PFZO-NP1573DA84000600 / RG-P-CBS series

Luminaire type	Surface-mounted, ceiling*, batten, 1573mm, opal PC.
Light source; Output	LED 41W, 4000K; 45.5W, 5940 lm*
IP Rating	IP66

*Ceiling mounting without additional accessories. Horizontal wall mounting with accessory ZBS-W (order separately). Pendant mounting using ZBS-SK wire (please order separately), note ceiling loop not included (to be provided by site.)

LINIA LUMINAIRE MODULE (Gear Tray, 1500mm*)

VLGFP1501-11CBWS840B0450 / RG-P-CBS series

Luminaire type	Linia-mounted, Linear fresnel optic, B wide beam
Light source; Output	LED 25W, 4000K; 28W, 4400 lm*
IP Rating	IP54

VLGFL1501-11CBWS840B0450 / RG-P-CBS series

Luminaire type	Linia-mounted, Lensed optic for low glare, wide beam
Light source; Output	LED 22W, 4000K; 24W, 4460 lm*
IP Rating	IP54

VLGFS1501-11CBWS84MP0400 / RG-P-CBS series

Luminaire type	Linia-Mtd, Wide MPS optic for all-round glare control
Light source; Output	LED 26W, 4000K; 30W, 4020 lm*
IP Rating	IP54

*Other gear tray lengths, optic ranges, beam angles, CCT & outputs are available. ** WS White finish as standard, Silver (-SI) or Black (-SW) finish available on request. Part no. if for the gear tray only, Linia trunking/kits must be ordered separately.

97-0430724/CB



97-0430732/CB



97-0832975/CB



97-0331317/CB



97-0331333/CB



97-0960087/CB



97-1561143/CB (White)**



97-1561158/CB (White)**



97-1561266/CB (White)**



RG-PERFORMANCE CBS

RG-P-CBS EMERGENCY ESCAPE LUMINAIRES

EXIDA-ACC-Performance / RG-P-CBS series

Luminaire type	Surface or Recessed-mounted, ceiling, OA, CO lenses
Light source; Lum. Flux	LED 3W; 140 lm
IP Rating	IP40

97-EXACP AL CBW* (White, Cw OA & CO lens)



EXIDA-Performance / RG-P-CBS series

Luminaire type	Recessed-mounted, ceiling, OA, CO, EP (point) lenses
Light source; Lum. Flux	LED 2W; 180 lm Nominal
IP Rating	IP30

97-EXPE AL CB W* (White; Cw OA, CO & EP lens)



EXIDA-ACC-Performance IP65 / RG-P-CBS series

Luminaire type	Surface-mounted, ceiling, OA, CO or HB (hi-bay) lens
Light source; Lum. Flux	LED 2W; 218 lm (OA), 206 lm (CO), 177 lm (HB)
IP Rating	IP65

97-EXACIP OA/(CO/HB)CBW (White; Cw 1 lens)



EXIDA-Performance IP65 / RG-P-CBS series

Luminaire type	Recessed-mounted, ceiling, OA, CO or EP (point) lens
Light source; Lum. Flux	LED 2W; 162 lm (OA), 160 lm (CO), 180 lm (EP)
IP Rating	IP65

97-EXIP OA/(CO/EP) CB W* (White; Cw 1 lens)



EXIDA-Premium OA / RG-P-CBS series

Luminaire type	Recessed-mounted, ceiling, OA lens
Light source; Lum. Flux	LED 3W; 225 lm
IP Rating	IP54

97-EXPR OA CB W* (White; Cw OA lens)



EXIDA-Premium CO / RG-P-CBS series

Luminaire type	Recessed-mounted, ceiling, CO lens
Light source; Lum. Flux	LED 3W; 232 lm
IP Rating	IP54

97-EXPR CO CB W* (White; Cw CO lens)



EXIDA-Essence OA / RG-P-CBS series

Luminaire type	Recessed-mounted, ceiling, OA lens
Light source; Lum. Flux	LED 2W; 123 lm
IP Rating	IP20

97-EXES OA CB W* (White; Cw OA lens)



EXIDA-Essence CO / RG-P-CBS series

Luminaire type	Recessed-mounted, ceiling, CO lens
Light source; Lum. Flux	LED 2W; 155 lm
IP Rating	IP20

97-EXES CO CB W* (White; Cw CO lens)



*'W' White finish as standard, 'B' Black finish on request where indicated

AXILUM (BULKHEAD ONLY) / RG-P-CBS series

Luminaire type	Surface-mounted, ceiling, wall, wide distribution
Light source	LED 3W; 150 lm
IP Rating	IP65

97-AXILUM/CB



Add '/LEG' for self-adhesive legend kit; See '/DDS' for drop-diffuser version.

LINIA EMERGENCY ESCAPE LUMINAIRE MODULE

LINIA VLMF-NL-BNT 500 / RG-P-CBS series

Luminaire type	Linia Integrated, 500mm module, OA, CO optics
Light source	LED 3W, 240 lm Nominal
IP Rating	IP54

97-VLMF-NL CB (White*)



*White finish as standard, Silver (-SI) or Black (-SW) available on request

RG-PERFORMANCE CBS

RG-P-CBS ESCAPE ROUTE LUMINAIRES

Q-SIGN FIXED SMALL / RG-P-CBS series

Luminaire type	Surface-mounted, wall, ceiling
Light source; View. Dist.	LED 2.6W; 25 m
IP Rating	IP40

Q-SIGN FIXED LARGE / RG-P-CBS series

Luminaire type	Surface-mounted, wall, ceiling
Light source; View. Dist.	LED 3.1W; 30 m
IP Rating	IP40

Q-SIGN PENDANT SMALL / RG-P-CBS series

Luminaire type	Surface-mounted Wire Suspended, ceiling
Light source; View. Dist.	LED 2.6W; 25 m
IP Rating	IP40

Q-SIGN PENDANT LARGE / RG-P-CBS series

Luminaire type	Surface-mounted Wire Suspended, ceiling
Light source; View. Dist.	LED 3.1W; 30 m
IP Rating	IP40

*Specific EC/ISO legends & /DS double sided versions are available on request.
 /RB Recessing bracket accessories are available for Q-sign (order separately)

SQL-SIGN RECESSED / RG-P-CBS series

Luminaire type	Recessed-mounted, ceiling
Light source; View. Dist.	LED 4.8W; 20 m
IP Rating	IP20

SQL-SIGN WALL / RG-P-CBS series

Luminaire type	Surface-mounted, wall
Light source; View. Dist.	LED 4.8W; 20 m
IP Rating	IP20

SQL-SIGN PENDANT / RG-P-CBS series

Luminaire type	Recessed-mounted Wire suspended, ceiling
Light source; View. Dist.	LED 4.8W; 20 m
IP Rating	IP20

*White finish as standard, /GR grey finish on request.
 **Choice of ISO Left (ISOAL)/ Right (ISOAR)/ Up (ISOAU), or, EC Left (ECAL)/ Right (ECAR)/ Down (ECAD) Arrow Legend formats.
 /DS double sided versions are available on request.
 /ROD Rod suspended/Recessed-gear mounted version available on request.

U-SIGN PENDANT / RG-P-CBS series

Luminaire type	Surface-mounted* Wire suspended, ceiling
Light source; View. Dist.	LED 2W; 32 m
IP Rating	IP20

*White plastic gear box can be surface mounted or recessed (no accessories)
 **Choice of ISO Left (ISOAL)/ Right (ISOAR)/ Up (ISOAU), or, EC Left (ECAL)/ Right (ECAR)/ Down (ECAD) Arrow Legend formats.
 Comprises double sided engraved & printed legend.

AXILUM DDS (Cw Drop Diffuser) / RG-P-CBS series

Luminaire type	Surface-mounted**, ceiling
Light source; View. Dist.	LED 3.2W; 32 m
IP Rating	IP65

*Choice of ISO Left & Right (ISOAR)/ Up (ISOAU), or, EC Left & Right (ECAR), / Down (ECAD) Arrow Legends for DDS deep, double-sided, drop exit sign diffuser.
 **/EBAX/RB Semi-recessing bracket accessories are available (on request)

97-QSN/ESA08/CB (CW set of EC/ISO legends*)



97-QSN/ESA10/CB (CW set of EC/ISO legends*)



97-QSN/ESA09/CB (CW set of EC/ISO legends*)



97-QSN/ESA11/CB (CW set of EC/ISO legends*)



97-SQL/RECE/CB/WH*/XXXXX (Cw 1 legend)**



97-SQL/WBRK/CB/WH*/XXXXX (CW 1 legend)**



97-SQL/WIRE/CB/WH*/XXXXX (CW 1 legend)**



97-USMZ/CB/XXXXX (Cw 1 DS legend)**



97-AXILUM/DDS/XXXXX*/CB (Cw 1 DDS legend)



RG-PERFORMANCE CBS

ARKTIK-SIGN / RG-P-CBS series

Luminaire type	Surface-mounted, wall
Light source; View. Dist.	LED 4.2 W; 30 m
IP Rating	IP42

*Choice of ISO Left (ISOAL)/ Right (ISOAR)/ Up (ISOAU), or, EC Left (ECAL)/ Right (ECAR)/ Down (ECAD) screen printed arrow Legend formats.

97-ARK/CB/WH/XXXXX* (Cw 1 legend)



F-LINE EXIT / RG-P-CBS series

Luminaire type	Surface-mounted, wall
Light source; View. Dist.	LED 3.1 W; 25 m
IP Rating	IP20

*/WH White finish as standard, /SG Textured Silver grey finish on request.
 **Choice of ISO Left (ISOAL)/ Right (ISOAR)/ Up (ISOAU), or, EC Left (ECAL)/ Right (ECAR)/ Down (ECAD) Arrow Legend formats.

97-MX/CB/WH*/XXXXX (Cw 1 legend)**



U-LINE-NL / RG-P-CBS series

Luminaire type	Surface/Pendant-mounted*, ceiling
Light source; View. Dist.	LED 1W; 32 m
IP Rating	IP40

*requires accessories for Pendant mounting (not inc., order separately)
 NE natural anodised standard finish. Special RAL requests are subject to quantity.
 **Choice of ISO Arrow Legend B (Down) or C (L/R). Specials subject to quantity.

U-LINE-NL-LED B/C CB NE (Cw 1 legend)**



VENICE-A-NL / RG-P-CBS series

Luminaire type	Surface/Recessed-mounted*, wall
Light source; View. Dist.	LED 1W; 32 m
IP Rating	IP40

*requires accessories for Pendant mounting (not inc., order separately)
 NE natural anodised standard finish. Special RAL requests are subject to quantity.
 **Choice of ISO Arrow Legend B (Down) or C (L/R). Specials subject to quantity.

VENICE-A-NL-LED B/C CB NE (Cw 1 legend)**



VENICE-E-NL / RG-P-CBS series

Luminaire type	Surface/Recessed-mounted*, ceiling
Light source; View. Dist.	LED 1W; 32 m
IP Rating	IP40

*requires an accessory for Recessed mounting (not inc., order separately)
 NE natural anodised standard finish. Special RAL requests are subject to quantity.
 **Choice of ISO Arrow Legend B (Down) or C (L/R). Specials subject to quantity.

VENICE-A-NL-LED B/C CB NE (Cw 1 legend)**



LINIA EMERGENCY ESCAPE ROUTE LUMINAIRE MODULE

LINIA VLMF / RG-P-CBS series

Luminaire type	Linia Integrated, 500mm module, Rotational fixing
Light source	LED 3W, 32 m
IP Rating	IP20

*Choice of ISO Arrow Legend B (Down) or C (L/R). Specials subject to quantity.
 ** White finish as standard, Silver (-S) or Black (-SW) finish available on request

VLMF-HW-B/C* CB (Cw 1 legend; White)**



RIDI Lighting Ltd
 8/9 The Marshgate Centre. Parkway, Harlow Business Park, Harlow, Essex. CM19 5QP
 Tel: +44 (1279) 450882 | Fax: +44 (1279) 451169
 www.ridi-linia.co.uk | info@ridi.co.uk

Whilst every care has been taken in compiling this brochure, errors or misprints may occur. We reserve the right to change design and technical details.

LED technology is in a continuous process of improvement. The specified efficiency values are provided as an illustrative example and reflect the state of the art at the time of going to print. Updated values can be accessed at any time at our website.